

NFC-504P

LCD FIRE ALARM CONTROL PANEL

NFC-504P 4 ZONE CONVENTIONAL FIRE ALARM CONTROL PANEL

PRODUCT OVERVIEW

NEVERFIRE conventional fire alarm system is the ideal choice for protecting commercial buildings, small places like small enterprises, small schools, specialty stores, restaurants, and apartments, Although there are more technology developing systems like addressable system, wireless system, etc. NEVERFIRE conventional fire alarm system protects buildings' safety by dividing them into different zones and keeping an eye on them one by one. It works with a series of detecting devices and alarm devices, giving warning alarm to alert the nearby residents or rescuers. NEVERFIRE Conventional fire alarm system is simple to install, economical & can be compatible with other manufacturers' equipment Also, it doesn't have complicated wiring, just follow the wiring instruction, people that are not professionals can also finish the installing wiring quickly.

NEVERFIRE panels has been designed to EN54 part 2 and part 4.

NFC-504P certified CE QACE20241069 ⁽¹⁾ which play a vital role in ensuring that NEVERFIRE products placed on the market of the world are safe. NFC-504P certified ISO9001:2015⁽¹⁾ Quality management systems and requirements, which is global standard for trusted goods and services.

DESCRIPTION

NFC-504P panel is Microprocessor based Conventional Fire Alarm Control Panel which has 4 zones, These control panel designed for small to medium commercial, residential, multi-family, institutional and industrial occupancies. NEVERFIRE conventional control panels are available with 2,4&8 initiating circuits which may be extensively configured Via a simple front panel operated programming method. They are Compatible with conventional detectors, manual call points and normally open dry contact devices.

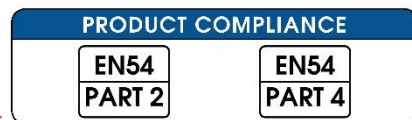
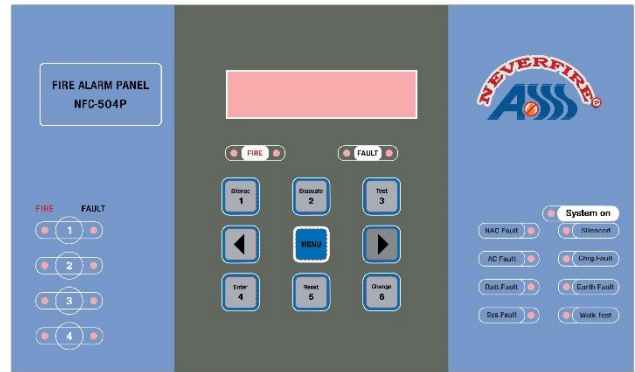
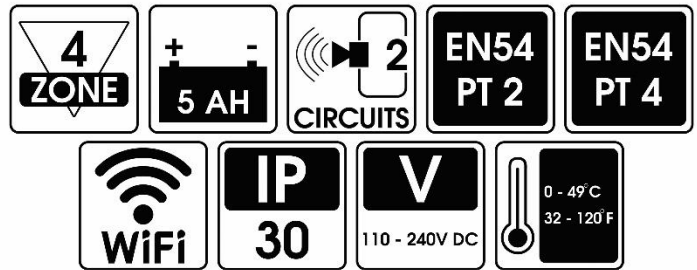

(1) you can view & download these certificates from ASSS website www.asss-eg.com

©2025 ASSS com., The company reserves the right to change the specifications of the products at any time and without prior notice. All information in this documents is given in good faith but ASSS com. Cannot be held Responsible for any omissions or errors. Printed in Egypt.

Issue: 001 Date: 2025/05/13 Page: 1 of 3





ISO9001

CE QACE202401069

NFC-504P

LCD FIRE ALARM CONTROL PANEL

FIRE DETECTION SYSTEM

STANDARD FEATURES
√ Four initiating circuits.
√ 16x2 dot matrix LCD display.
√ Lamp test facility.
√ Access via password – removes problem of lost keys.
√ 2 Class B notification appliance circuits (NAC).
√ All zones accept all types of conventional detectors and normal open contact devices.
√ Auto Signal Silence.
√ System ON indication.
√ Surface Mount Technology.
√ Over All current consumption is low.
√ Resettable\ Steady 24VDC Output.
√ Form C relays for fire and fault.
√ Earth fault annunciation facility at 0 ohms.
√ Standby (Battery) backup 24VDC power supply with built in charger (charging current 0.5A max).
√ Operates on 100-240VAC, 50\60Hz, AC mains 3A.
√ Maximum battery size 5Ah.
√ Auto Resettable Fuse.
√ Battery polarity reversible protection.
√ Battery low visual warning with audible tone.

MOUNTING DETAILS

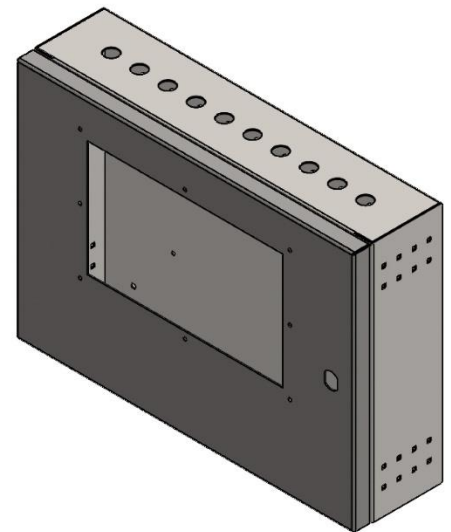
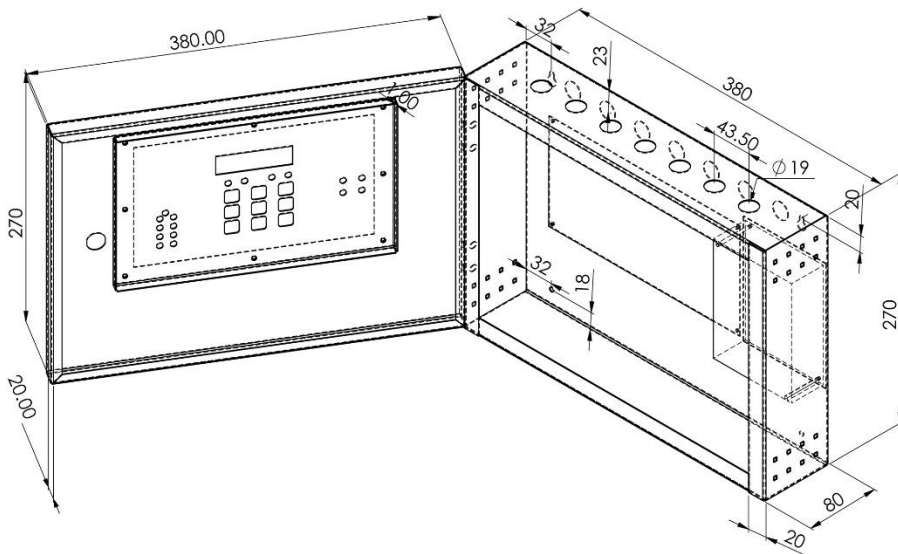

©2025 ASSS com., The company reserves the right to change the specifications of the products at any time and without prior notice. All information in this documents is given in good faith but ASSS com. Cannot be held Responsible for any omissions or errors. Printed in Egypt.

Issue: 001

Date: 2025/05/13

Page: 2 of 3

AL ALAMIA FOR SAFETY & SECURITY SYSTEMS COM. (ASSS)

Factory: 16C, south industrial Zone, 10th of Ramadan City, Sharkyia, Egypt.

Administration: No.6, 163 St, Behind the military hospital, El Maadi, Cairo, Egypt.

TEL.: +2 02 25249113

FAX.: +2 02 25281778

MOBILE: +2 01129277269

E-Mail: info@asss-eg.com

WWW.ASSS-EG.COM

ASSS FACTORY is the first manufacture for fire alarm system in Africa & middle east.

The com. established since 2011 located in cairo governorate while the factory located in Sharkyia governorate.

NFC-504P

LCD FIRE ALARM CONTROL PANEL

TECHNICAL SPECIFICATIONS	
ELECTRICAL SPECIFICATIONS	
MODEL NUMBER	NFC-504P.
Supply Voltage	100-240VAC± 10%, 50Hz.
System Voltage	24V DC (Nominal) 3A.
Zone Voltage	21V DC (Nominal).
AC Supply Fuse	3 Amp 250V 20mm.
Fault Relay	1 x Volt Free Relay, SELV@1A Max.
Fire Relay	1 x Volt Free Relay, SELV @1A Max.
Battery cut off	Battery voltage less than 20V.
Maximum battery Space	2 x 5 Ah, 12 Vdc sealed lead acid.
NAC Rating	0.5A per Circuit 1A Total.
Detection Zone Current	1.6mA.
Detection Zone EOL Resistor	3k9 5%, 1\4watt.
NAC EOL Resistor	3K9 5%, 1\4watt.
Communication	WiFi (Option)
Cable Capacity	14 AWG
OPERATING CONDITION	
Operating Temperature	0 - 49°C \ 32 - 120°F.
Storage Temperature	0°C - 60°C.
Relative Humidity	93 ± 2% RH (non-condensing) at 32±2°C \ 90±3°F.
MECHANICAL SPECIFICATIONS	
Cable Entry	7xø19mm Knockout on top of the cabinet. 7xø19mm Knockout on backside of the cabinet.
IP Rating	IP30.
Dimensions	380.00W x270.00H x 80.00D mm.
Construction	1.00 mm Cold-Rolled Steel grade 37 (ST37).
Color	Grey Ral 7035 \ Red Ral 3020.
Weight	5Kg (Excluding Batteries).
Carton Dimensions	520*365*160 mm.

WARRANTY

NEVERFIRE warrants that product from defects in design, materials and workmanship during the warranty period ensuring customers' confidence in product quality and performance.

For comprehensive information, including installation guidelines and compatibility details, please consult NEVERFIRE Installation Manual or reach out to our technical support team. Anybody, including the agents, distributors or employees, is not in the position to amend the contents of this warranty.

©2025 ASSS com., The company reserves the right to change the specifications of the products at any time and without prior notice.

All information in this documents is given in good faith but ASSS com. Cannot be held Responsible for any omissions or errors. Printed in Egypt.

Issue: 001

Date: 2025/05/13

Page: 3 of 3

AL ALAMIA FOR SAFETY & SECURITY SYSTEMS COM. (ASSS)

Factory: 16C, south industrial Zone, 10th of Ramadan City, Sharkyia, Egypt.

Administration: No.6, 163 St, Behind the military hospital, El Maadi, Cairo, Egypt.

TEL.: +2 02 25249113

FAX.: +2 02 25281778

MOBILE: +2 01129277269

E-Mail: info@asss-eg.com

WWW.ASSS-EG.COM

ASSS FACTORY is the first manufacture for fire alarm system in Africa & middle east.

The com. established since 2011 located in cairo governorate while the factory located in Sharkyia governorate.